

	GLOBAL STANDARD	Page 1 of 21
	MV/LV TRANSFORMERS AMENDMENT 9 GST001-2018	GST001 - 2018 Rev. 03 Amendment 9 15/07/2020

MV/LV TRANSFORMERS AMENDMENT 9 GST001 - 2018

Countries I&N	Elaborated by
Argentina	
Brazil	R. MoreiraSales;
Chile	
Colombia	
Spain	
Italy	
Peru	
Romania	

	Elaborated by	Verified by	Approved by
Global I&N – O&M/NCS	G. Andreella J. M. Rey Sanchez	F. Mauri	M. Mazzotti

This document is intellectual property of Enel SpA; reproduction or distribution of its contents in any way or by any means whatsoever is subject to the prior approval of the above mentioned company which will safeguard its rights under the civil and penal codes.

Revision	Data	List of modifications
00	12-8-19	First emission

	GLOBAL STANDARD	Page 2 of 21
	MV/LV TRANSFORMERS AMENDMENT 9 GST001-2018	GST001 - 2018 Rev. 03 Amendment 9 15/07/2020

1 SCOPE

The scope of this document is to update some specific requirements of the Global Standard GST001 rev. 03 - 31/1/2018.

The parts of the GST001 which are updated by the present document are hereby reported with the corresponding clauses and sub-clauses number.

The present amendment replace the corresponding prescriptions in the GST001 in force, wherever applicable and unless otherwise specified

This amendment apply to the following distribution company of Enel Group:

- Enel Distribuição São Paulo (SP) Brazil
- Enel Distribuição Ceará (CE) Brazil
- Enel Distribuição Goiás (GO) Brazil
- Enel Distribuição Rio (RJ) Brazil

4 SERVICE CONDITIONS

Unless otherwise specified the normal service conditions defined in IEC 60076-1 apply with the following exceptions:

Characteristic	Enel Distribuição São Paulo	Enel Distribuição Ceará	Enel Distribuição Goiás	Enel Distribuição Rio
Altitude (m)	<1000	<1000	<1000	<1000
Pollution level (IEC 60815)	Medium	Extra Very High	Medium	Extra Very High
Seismic activity	No	No	No	No

LOCAL SECTION A – BRAZIL: Enel Distribuição Ceará, Enel Distribuição Goiás, Enel Distribuição Rio e Enel Distribuição São Paulo

In addition on what specified in the common part, the following requirements are prescribed:

3.2 INTERNATIONAL STANDARDS
IEC 60068: Environmental test
3.3 LOCAL STANDARDS
NBR 5440: Distribution transformers – Requirements (Support test). NBR 15422: Insulating vegetable oil for electrical equipment Portaria Interministerial nº3, do Ministério de Minas e Energia de 31/07/2018.
3.4 LIST OF REPLACED STANDARDS
GST001 R03

5.10 INSTALLATION

Country	Mounting System		
	Single-Pole	Double-pole	Surface Level
Brazil	≤ 300 kVA	not used	not used

Table A1 – Mounting system

For Enel Distribuição São Paulo the following groups of connections should be considered:

Groups	Taps MV (V)	Dispatch voltage (V)	LV (V)
G	7967 / 7621 / 7275	7621	240/120
H	7967 / 7621 / 7275 / 2320 / 2210 / 2100	2210	
I	13972 / 13337 / 12702	13337	
M	13800 / 13200 / 12600/12000/11400	13200	220/127
M/L	13800 / 13200 / 12600 / 3985 / 3785 / 3585	3785	
O	23100 /22000 / 20900	23100	

Table A2 – Groups

The transformers with plug-in MV Bushing are installation indoor. The transformer will be installed in modular center standard in MAT-OMBR-MAT-18-0085.

5.11 INSULATION LEVELS

Note: the exception of insulation levels for single-phase transformers (1P) of 7,967 kV as requirement of the standard NBR 5440 (Brazil) considering a maximum voltage of 17.5 kV therefore is considered in the common list the isolation levels 17.5/95/38kV.

For Enel Distribuição Goiás maximum voltage of 36,2 kV therefore is considered in the common list the isolation levels 36,2/150/50kV

For Enel Distribuição São Paulo maximum voltage of 24 kV therefore is considered in the common list the isolation levels 24,2/125/50kV

5.12 LOSSES, SHORT CIRCUIT IMPEDANCES AND SOUND POWER LEVELS

The values for the short circuit impedance, referred to 75 ° C, shall be as shown in Table A3 with tolerance of ± 10% that sets the standard IEC 60076-1.

Rated Power Transformer [kVA]	Short circuit impedance, referring to 75 ° C [%]
single-phase and double-phase	
≤ 25	2 ÷ 4
Three-phase	
≤ 300	4
≥ 500	5

Table A3 – Short circuit impedance

The losses value must be the minimum values between those indicated in this document and those indicated legislation of Brazil.

5.16 OVERALL DIMENSIONS AND LAYOUT

See Common List TR MV/LV and Figure A1, Figure A2 and Figure A3 which define the maximum dimensions for the length, the width (depth) and the height of transformers and the layout of the main elements (bushings, supports, anchoring bases or wheels).

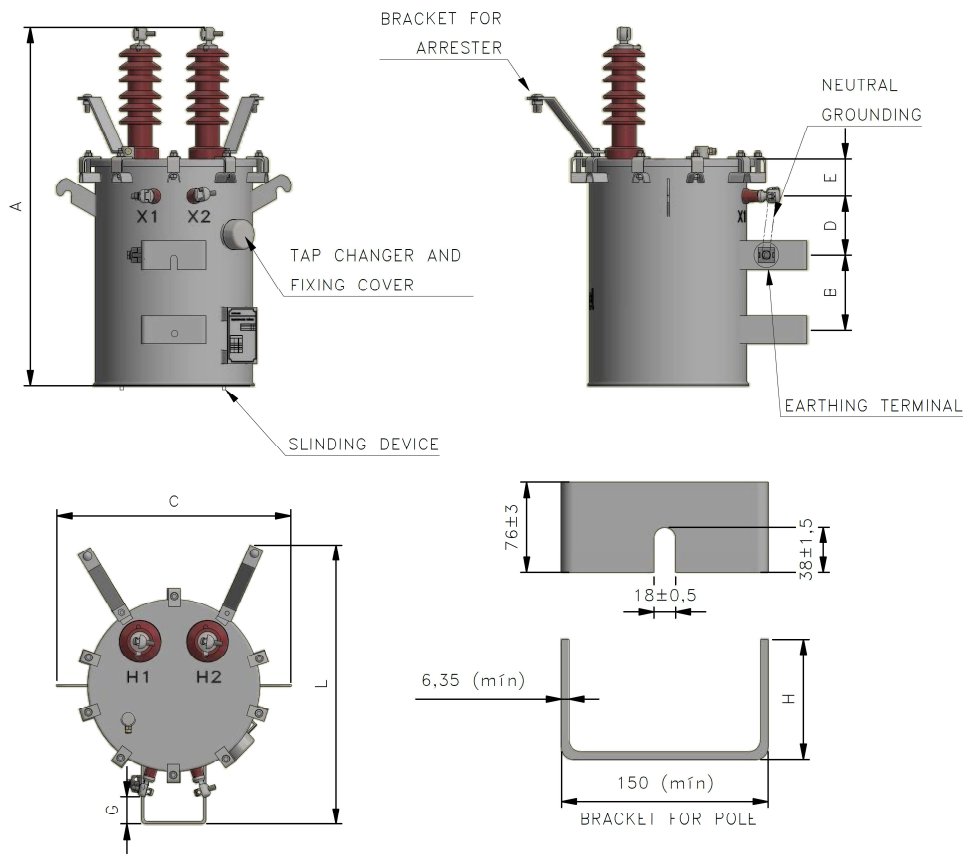

Figure A1 : Dimensions to single-phase and two-phase transformer.

NOTE: The transformers may have one or two MT bushings and two or three BT bushings (center tap).

		15kV		24,2 or 36,2 kV	
		P ≤ 37,5	P > 37,5	P ≤ 37,5	P > 37,5
Maximum dimensions	A	1200	1400	1300	1700
	C	800	900	800	900
	L	900	1000	900	1000
Minimum dimensions	G	50	50	50	50
Tolerance D e B ±5% E ± 10% H ±0,5%	D	120	150	120	150
	B	200	400	200	400
	E	100	100	100	100
	H				

P = Rated Power Transformer [kVA]

Table A4 – Single-phase and Two-phase Transformer dimensions

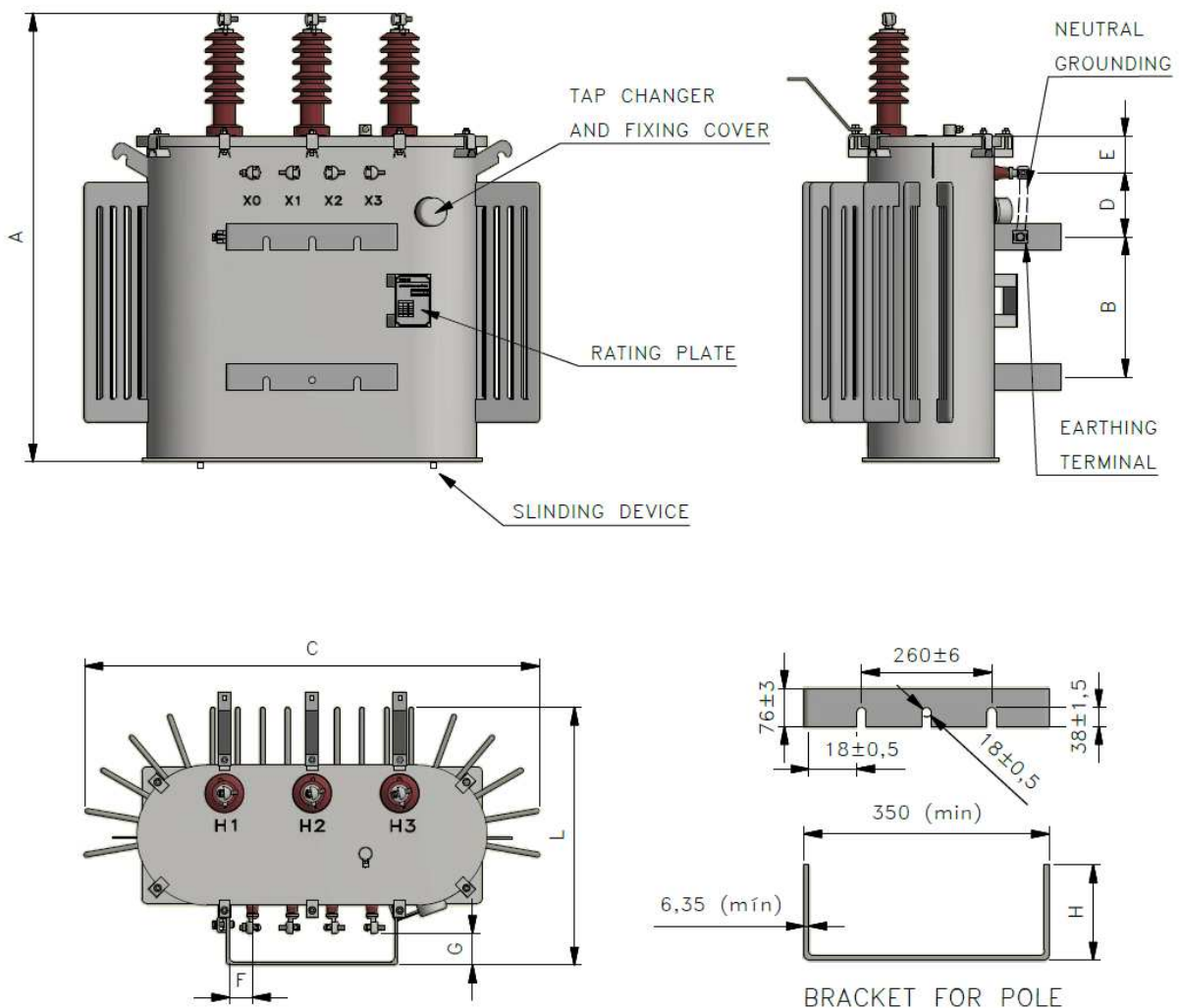

Figure A2 : Dimensions to three-phase transformer.

		15kV			24,2 or 36,2 kV		
		P ≤ 45	45 < P ≤ 150	P > 150	P ≤ 45	45 < P ≤ 150	P > 150
Cotas máximas	A	1300	1300	1800	1600	1600	2000
	C	1300	1350	1650	1400	1450	1700
	L	750	950	1150	900	950	1200
Cotas mínimas	G	50	50	50	50	50	50
	F	65	65	65	65	65	65
Tolerâncias D e B ±5% E ± 10%	D	120	150	150	120	150	150
	B	200	200 ou 400	400	200	200 ou 400	400
	E	100	100	100	100	100	100

Table A5 – Three-phase transformer dimensions

NOTE:

- *There must be at least an horizontal distance of 50 mm between the bracket and the outer part of the BT Bushing*
- *The maximum weight to 150 kVA is 750 kg and to transformers of 300 kVA is 1200 kg.*
- *The H dimension should be as indicated in Figures A1 and A2.*
- *The transformer is install at pole with central holes.*

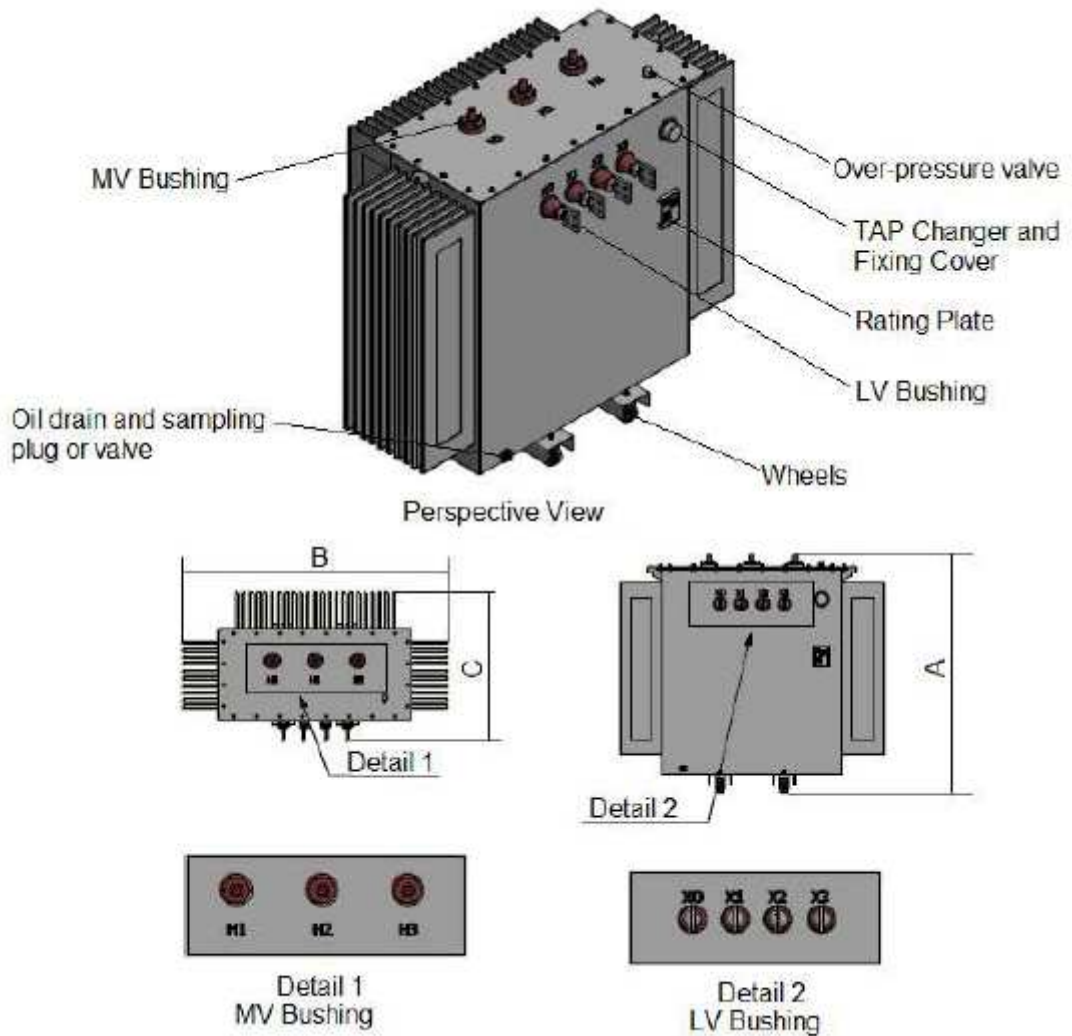

Figure A3 : Dimensions to three-phase transformer

		Rated Power				
		30 kVA	400 kVA	630 kVA	800 kVA	1000 kVA
Dimensions (mm)	A	1300	1850	1850	1850	1850
	B	1300	1600	1800	1800	1800
	C	750	1030	1030	1030	1030

Table A6 – Transformer dimensions

	GLOBAL STANDARD	Page 8 of 21
	MV/LV TRANSFORMERS AMENDMENT 9 GST001-2018	GST001 - 2018 Rev. 03 Amendment 9 15/07/2020

6.3 TANK

The active part, which is mounted to the tank walls, should have devices (hooks, holes, or others) that facilitate its removal and placement. These devices should be symmetrical and guarantee lifting without horizontal movement; and they should be different from the tank fastening supports.

6.4 INSULATING LIQUID AND MATERIAL

Class “T” oil according to table 2 of IEC 60296. The use of paraffinic or naphthenic oil is permitted, according to the manufacturer’s offer.

Alternatively, and only in the cases where required, silicone, mineral or vegetable oils with a high flammability point, according to the manufacturer’s offer, may be requested.

The vegetable oil may be standard NBR 15422.

SOLID INSULATING MATERIAL

For Enel Distribuição Ceará, Enel Distribuição Goiás, Enel Distribuição Rio and Enel Distribuição São Paulo the solid insulating material, of heat stable paper (equal or higher than Class “E” 120°C) will be required.

GASKETS

Seal materials of transformers should be nitrite rubber or higher, in accordance with ASTM D297, ASTM D2240 and ASTM D471

WEIGHT

The maximum weights to transformers admitted are:

Rated power ≤ 150 kVA: 950 kg.

150 kVA < Rated power ≤ 300 kVA: 1500 kg.

300 kVA < Rated power ≤ 630 kVA: 2700 kg

Rated power > 630 kVA: No specific limits.

6.5 BUSHINGS

The MV bushing for transformers in Figure A1 and A2 is considered to Brazil the solution 6 considering porcelain or silicon rubber polymer as IEC 60137, see Figure A3, and may be bolted either on or under the cover, according to the manufacturer's offer.

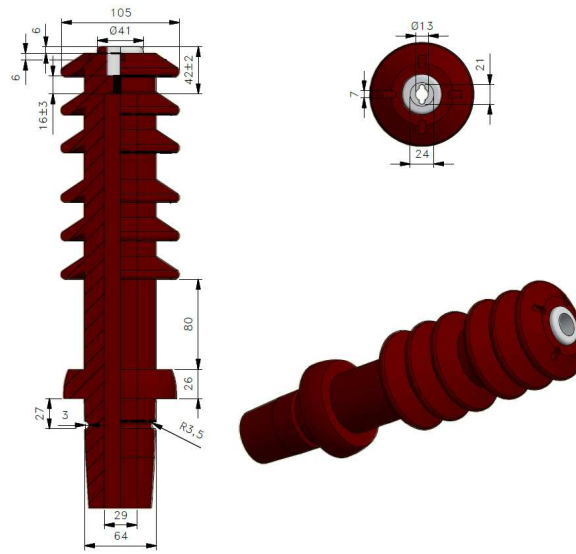

Figure A4 : MV Bushing

For Enel Distribuição São Paulo, for transformers with voltage up to 15kV(except M group GST001/905, 907, 908 and 909), the bushings of MV should be 15kV according to Figure A4. For transformer in M group (GST001/905, 907, 908 and 909), the bushing of MV should be as indicated in the Figure A4

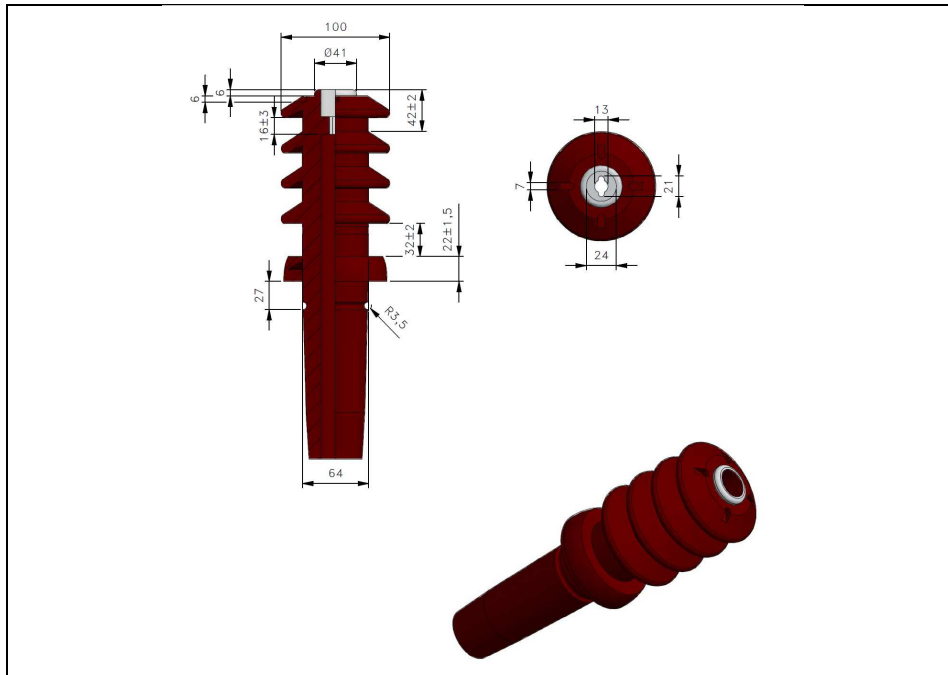

Figure A5 : MV Bushing 15kV

The MV terminal connector for MV bushing standard in Figure A4 and Figura A5 must be Figure A6.

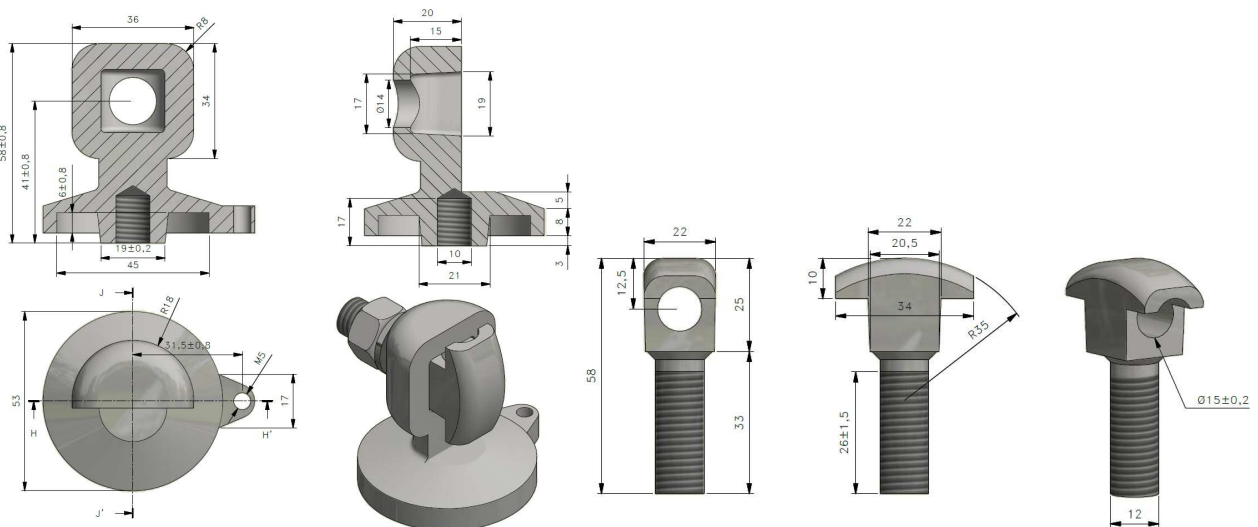

Figure A6 : MV terminal

The LV bushing for transformers in Figure A1 and A2 is considered to Brazil the solution 8 considering porcelain or epoxy as IEC 60137, or porcelain insulators and terminals according to DIN42530 standard NEMA or where indicated, see Table A7

Capacity [kVA]	ENEL DISTRIBUIÇÃO CEARÁ	ENEL DISTRIBUIÇÃO GOIÁS	ENEL DISTRIBUIÇÃO RIO	ENEL DISTRIBUIÇÃO SÃO PAULO
≤75kVA	Locking connector	Locking connector	Blade connector (NEMA 2)	Blade connector (NEMA 2)
>75kVA and ≤150kVA	Blade connector (NEMA 4)	Blade connector (NEMA 4)	Blade connector (NEMA 4)	Blade connector (NEMA 4)
>150kVA	Blade connector (NEMA 4)	Blade connector (NEMA 4)	Blade connector (NEMA 4)	Blade connector (NEMA 4)

Table A7 - Type of low voltage terminal connectors

The LV bushing must be located in front part of the same side of the bracket.
For LV terminal Locking connector, see Figure A7.
For LV terminal Blade connector (NEMA 2), see Figure A8.
For LV terminal Blade connector (NEMA 4), see Figure A9.

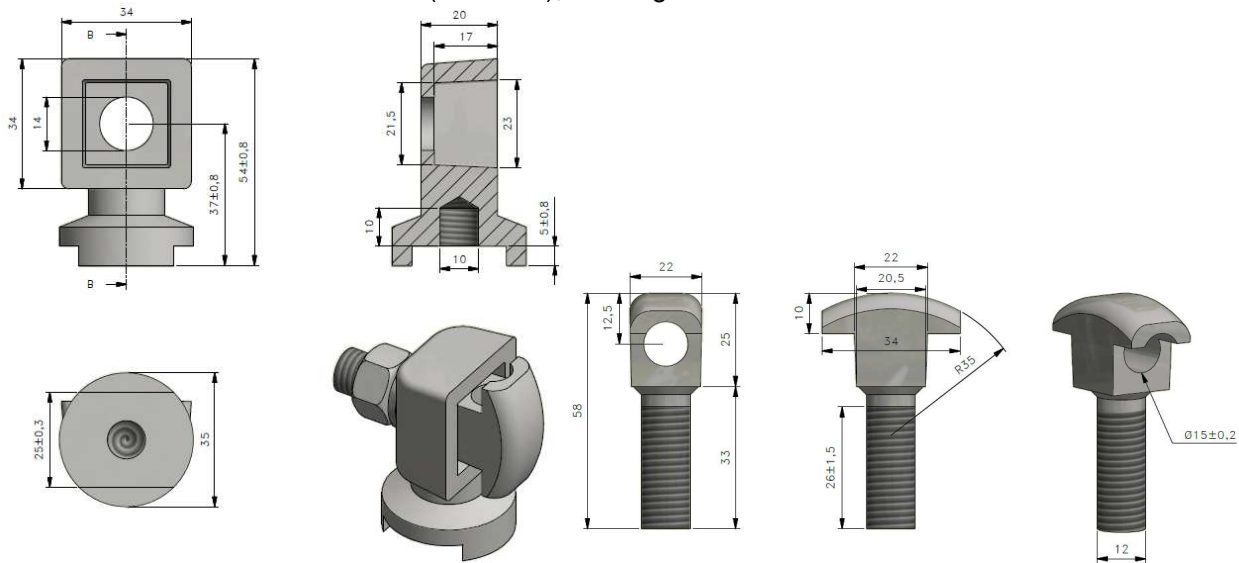

Figure A7 : LV terminal locking connector

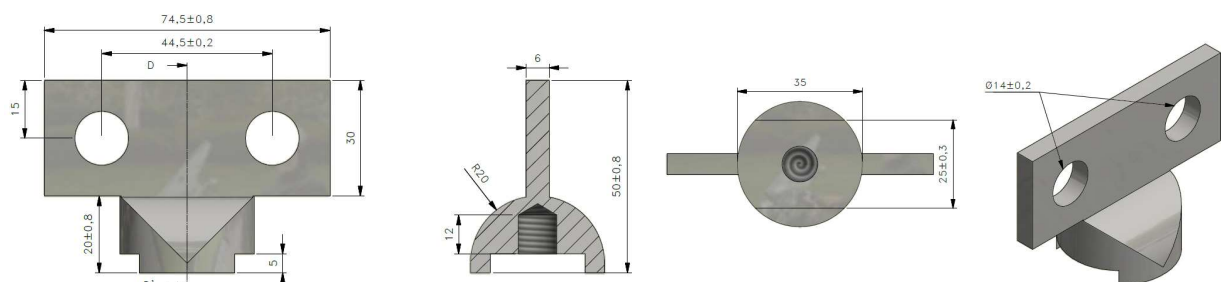

Figure A8 : LV terminal Blade connector (NEMA 2),

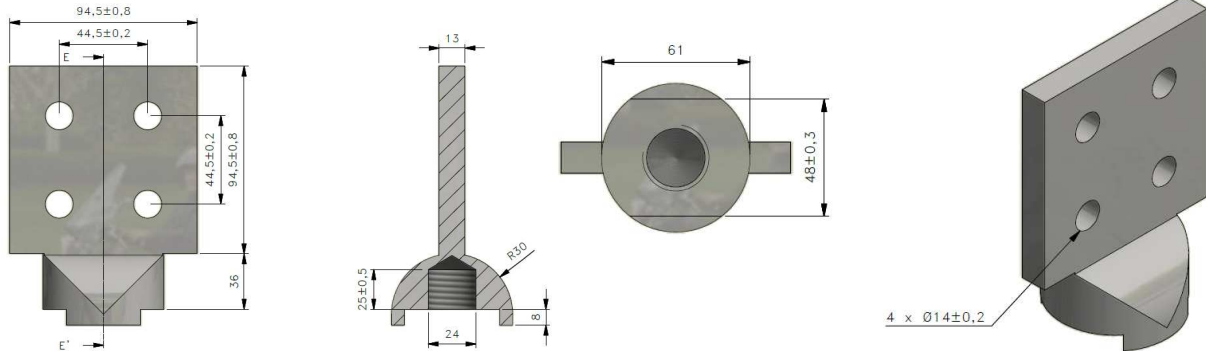

Figure A9 : LV terminal Blade connector (NEMA 4),

The MV bushing for transformer in Figure A3 is considered to Brazil the solution 4, see Figure A10.

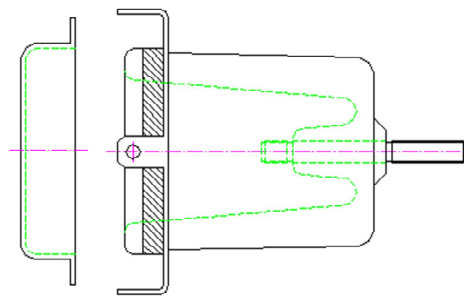

Figure A10 : MV Bushing

The LV bushing for transformer in Figure A3 is considered to Brazil the solution 8 considering porcelain or epoxy as IEC 60137, or porcelain insulators and terminals according to DIN42530 standard NEMA or where indicated, see Table A8.

Capacity [kVA]	Connector Type	
	380 V	220 V
30 kVA	Blade connector (Type 1)	Blade connector (Type 1)
400 kVA	Blade connector (Type 2)	Blade connector (Type 2)
630 kVA		
800 kVA	Blade connector (Type 3)	Blade connector (Type 3)
1000 kVA		

Table A8 - Type of low voltage terminal connectors

The LV bushing must be located in front part of the same side of the bracket.
For LV terminal Blade connector standard NEMA are indicated in Figure A11.

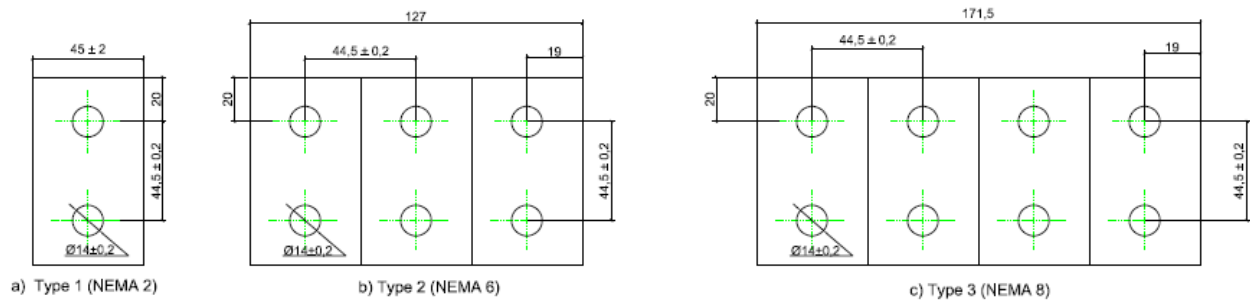

Figure A11 : LV terminal Blade connector (NEMA)

The LV terminal blade must have installed in LV bushing are indicated in Figure A12.

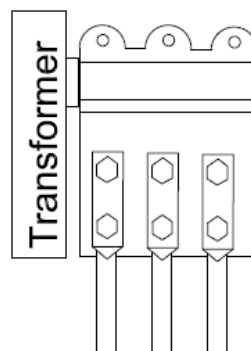

Figure A12 : Assembly detail

For companies exposed to an environment with pollution levels of High and Very High, epoxy bushings should be accompanied by certificates demonstrating the good performance of this material in this type of environment. The testing certificates to be submitted will correspond to those defined as special tests according to IEC60068:

- Saline mist cycle – 96 hours
- Heat and humidity cycle – severity of 40°C, 6 cycles.
- UV Rays
- Climatic sequence – method 1

Phase markings and identification

The sequence for each phase of the distribution transformer should be marked. The identification should be engraved in high relief or bas-relief, each phase painted color black. During the draft approval stage, details for the required markings and identification will be indicated.

	GLOBAL STANDARD	Page 14 of 21
	MV/LV TRANSFORMERS AMENDMENT 9 GST001-2018	GST001 - 2018 Rev. 03 Amendment 9 15/07/2020

6.6 DE-ENERGIZED TAP-CHANGER - DETC

The DETC will be located on the tank side and at the low voltage side installed to ensure tightness. The lid switch must be fixed to the tank in order to be unmissable. For Enel Distribuição São Paulo, it is allowed to use internal DETC for groups H and M/L. In these cases, the transformer must be provided with an inspection window at the top for access to the DETC.

6.8.1 SUPPORTING

The position of the mounting support (on the MV or LV) for single-pole mounted transformer must be fixing bracket in the LV side for all power values.

6.8.2 SLIDING DEVICES

For transformers in Figure A1 and A2 at the base of the tanks should be placed profiles which serve as fixing means and / or allowing a minimal height over the floor during storage, according to the weight of the equipment.

The transformer in Figure A3 are equipped with wheels without flanges, adjustable, in two perpendicular directions, for longitudinal and transversal displacements.

6.9 PAINTING

The color is RAL7038.
For transformer with vegetal oil the color is Munsell 5G 8/4

6.10.1 LIFTING AND BLOCKING DEVICES

Transformer shall be provided with Two hooks located in the top part of the tank. The hooks will allow fastening the suspension of the transformer, in such way as not to damage the bushing insulators of the terminals and accessories and ensure the suspension of the transformer in a horizontal position.

HOOK LIFTING OF THE ACTIVE PART

Two eyebolts or hooks designated for machine detanking shall be located: on the cover, when the LV bushing are fixed on it, or on the structure of the active part, when the LV bushings are fixed on the side of tank.

The eyebolts will allow fastening in such a way so as not to damage the bushing insulators of the terminals and ensure detanking with the cover in a horizontal position.

These eyebolts will be provided with blind holes for the purpose of dissuading their use for machine transport.

6.10.2 OIL DRAIN DEVICE AND SAMPLING PULG OR VALVE

For transformer in Figure A1 and A2 is not Required

The transformer in Figure A3 shall be provided with oil drain device and sampling plug or valve complying.

6.10.3 THERMOMETER POCKET

	GLOBAL STANDARD	Page 15 of 21
	MV/LV TRANSFORMERS AMENDMENT 9 GST001-2018	GST001 - 2018 Rev. 03 Amendment 9 15/07/2020

Not required
6.10.4 OVER PRESSURE VALVE
For totally filled transformers this accessory will not be required. For gas cushion transformers the over pressure valve is required for all power values.
6.10.5 OIL LEVEL INDICATOR
All power internal marking paint in the tank
6.10.6 SUPPORT FOR SURGE ARRESTER

The transformers in Figure A1 and Figure A2 must be provided of a support (one each phase) for the installation of medium voltage arresters, see Figure A13 e A14. The structures may be welded or bolted to the tank or fixed by the bolt, nut and washer of the tank-cover coupling hardware, according to manufacturer's design and approval of the distributor. The material used for brackets, bolts, nuts and washers shall be carbon steel hot dip galvanized. The surge arresters are not considered in the supply.

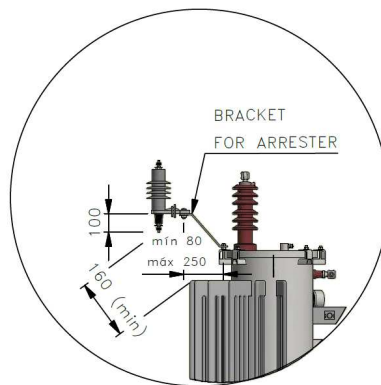

Figure A13 : Bracket for transformer with radiator

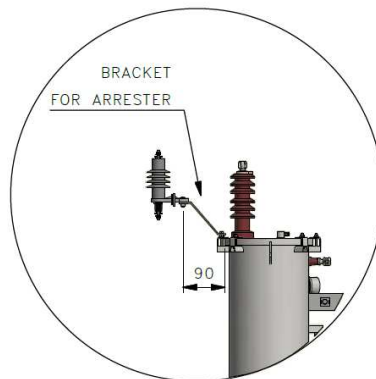
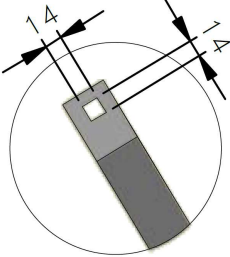
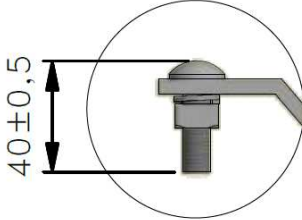

Figure A14 : Bracket for transformer without radiator

The drilling of the support surge arrester must be conform to Figure A11.

The bolt, nut and washer to fix the arrester should be part of the transformer supply. The minimum screw size is shown in Figure A12.

	 <p>DETAIL: SCREW M12x1,75</p>
Figure A15 : Bracket for transformer without radiator	Figure A16 : Bracket for transformer without radiator

6.10.7 EARTHING TERMINALS

These terminals shall be placed at the support fixed to tank. The terminal shall allow the connection of two cables from 10mm² to 70mm², see Figure A17. The transformers shall have a grounding connector. The terminal will have a hexagonal head screw, thread type M12x1.75 (diameter by length) and a washer, both made from stainless steel or brass, with a minimum copper content of 60%. In addition, the tin-plated bronze grounding connector (minimum 8µm) should be supplied.

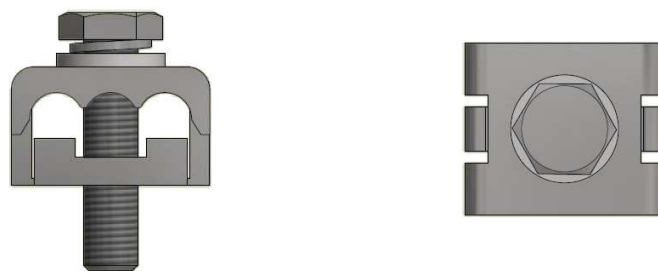

Figure A17 : Earthing terminal detail

6.10.8 RATING PLATES AND PLATE-HOLDERS

The nameplate language shall be in Portuguese.

The manufacturing serial number shall be punctured on the following points:

- nameplate;
- suspension hook, preferably the one to the right of an observer facing the LV bushing side;
- upper clamping bars of the core.

Note: The number should be engraved before the final paint and preferably before the anti-corrosive paint.

Additional to data requested in IEC standard must be added:

- Level noise
- Losses

	GLOBAL STANDARD	Page 18 of 21
	MV/LV TRANSFORMERS AMENDMENT 9 GST001-2018	GST001 - 2018 Rev. 03 Amendment 9 15/07/2020

- Winding material
- Serial number
- Purchase order number
- Date of manufacture (Day, Month, Year)

6.10.9 FILLING HOLE AND PLUG (FILLING CAP)

To allow for the completion of the leak test the transformer should have a small tube in the top ½” internal thread and plug for nitrogen filling.

9.1.5.2 CRITERIA FOR TYPE AND SPECIAL TESTS

Type tests

The selection of samples for type tests shall be two units by type of transformer. The rated power will be on agreement with the Distribution Company.

Special Test

Short-circuit test. The sample shall be one unit by type of transformer. The rated power will be on agreement with the Distribution Company.

NOTE. Type of transformer. Group of transformers which have the same voltage level in the primary side and the same kind of core, wrapped type or cold rolled . Transformers with dual voltage level on the primary side should be considered a different type.

9.1.4 SPECIAL TESTS

Test for support fixed to tank (NBR 5440). The support must be tested with the transformer installed only by the center screws.

10 TRANSPORT AND PACKING

The equipment should be individually packed onto treated wood or plastic pallets in a way suitable for transport, in such a way as to avoid any damage to equipment. The packing should be suitable for introducing equipment into standard transport industry containers. All additional elements of the equipment should be packed into a single crate.

Transformers should be transported with their complete oil load and accessories in place. The transformer should be completely secured in its packaging.

Wood should be treated according to international plague control requirements, avoiding compounds dangerous to human health or the environment, such as “pentachlorophenol” and “creosote”. The treatment should consider at least: high toxicity to xylophagous organisms, high penetrability and staying power, chemical stability, and substances which are non-corrosive to metals and which do not affect the physical characteristics of wood.

A visual inspection of the equipment will be carried out upon receiving it, checking for possible damage occurred during transport and the warehousing process. In addition, the presence of the complementary elements should be verified (clamps, grounding bolt, fuses, etc.)

Packaging should be able to withstand the weight produced upon stacking up to 3 single-phase and 2 three-phase transformers of normal capacity no higher than 150 kVA.

A list of the packaging brands should be submitted for the Client’s comments and final approval. The country of manufacture should be included in the packaging information.

12 FIGURES

PARTICULAR SCHEMES FOR BRAZIL

Transformer Identification:

For transformer without radiator: the power of the transformer, the coding and the name Enel must be located at the rear and horizontally arranged, see Figure A18.

For transformer with radiator: the power and coding must be located above the radiator and the name Enel below, see Figure A18.

NOTE 1: If the space above or below the radiator is insufficient, they should be located near the nameplate, with the vertical coding, the power and the name Enel horizontal.

NOTE 2: It is assumed that the name of Enel is located between the fastening brackets when it does not fit in the other recommended locations. In any case, the coding of the transformer must be easy to see whether it is in the ground or installed on a pole.

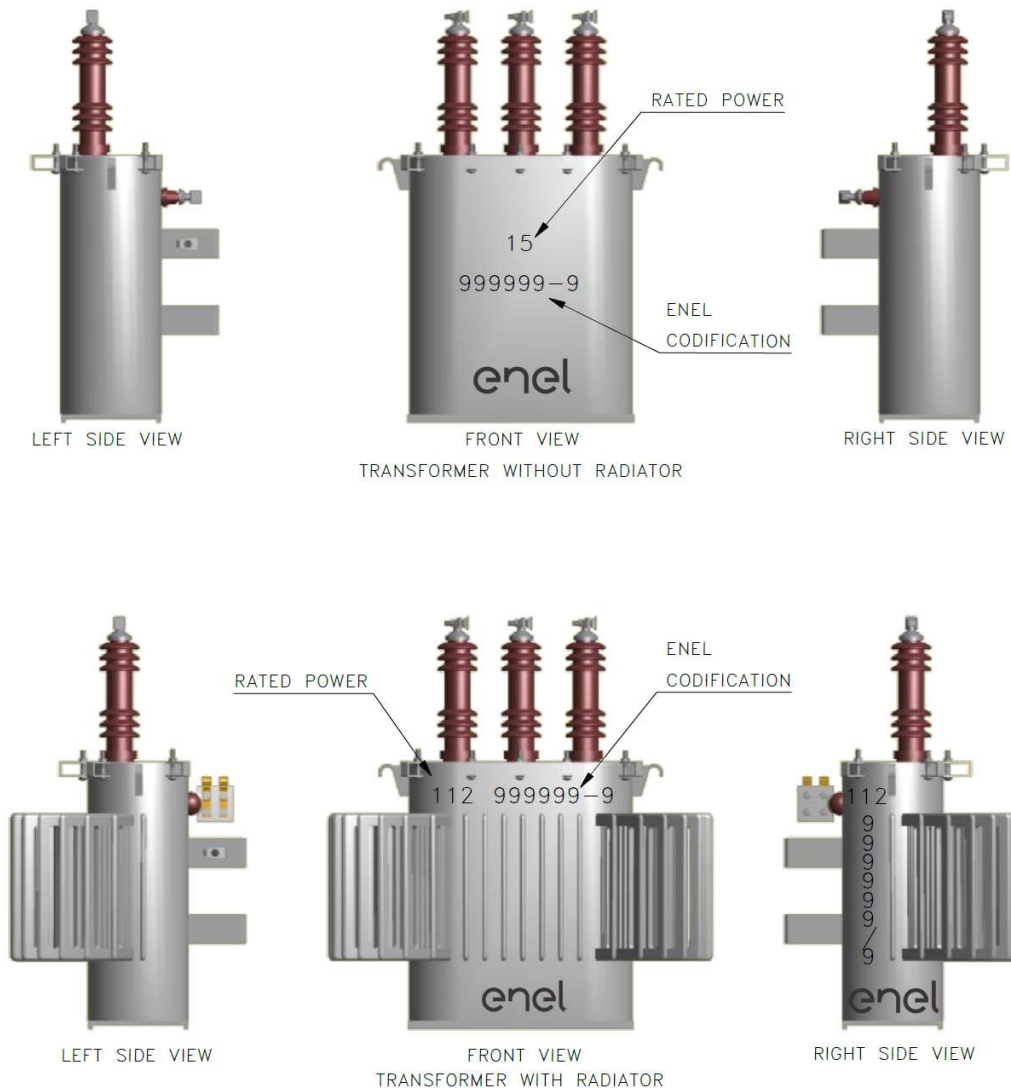

Figure A18 : Transformer Identification

The name Enel must have dimensions as shown in Figure A19. Further coding each digit of the encoding should have dimension of 35mm in height and 25mm in width.



Figure A19 : Name Enel

For Enel Distribuição São Paulo the phase marking must be according to Figure A20 and Figure A21. For Group M GST001/905, 907, 908 and 909, the rated MV voltage “13,8 kV” must be marked next H2:

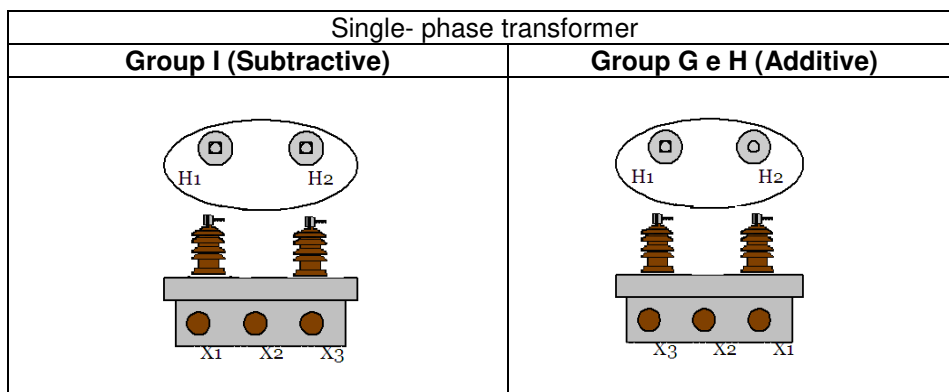

Figure A20 – Phase Markings single-phases

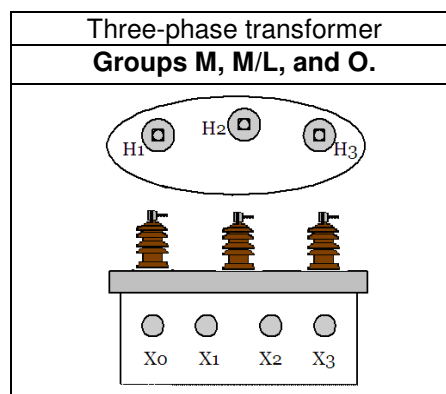

Figure A21 – Phase Markings three-phases

	GLOBAL STANDARD	Page 21 of 21
	MV/LV TRANSFORMERS AMENDMENT 7 GST001-2018	GST001 - 2018 Rev. 03 Amendment 9 15/07/2020

COMMON LIST

MV/LV TRANSFORMERS REFERENCE LIST is attached.